

Inhalation Exposure Assessment to Florida Red Tide Toxins and Blue Green Algae Toxins: High Volume and Personal Samplers for Dose Characterization

Yung Sung Cheng
Lovelace Respiratory Research Institute



Objectives

- **Characterize Aerosol**
 - PbTx/microcystin concentration, particle size and toxin profile
 - Relationship of PbTx air concentration with environmental conditions at the beach
- **Assess Exposure**
 - Personal exposure
 - Dose estimate
 - Correlation with health effects

Field Measurements

- **Environmental Conditions**
 - Temperature, RH, wind speed and wind direction
- **Water and Air Samples**
 - High-Volume Samplers (impactor, 8-h samples samples)
 - High-Volume Sampler (filter, hourly samples)
 - DataRAM Real-time sampler for concentration
- **Personal Exposure**
 - IOM Sampler
 - Biomarkers (swap/nasal lavage)

Environmental Conditions

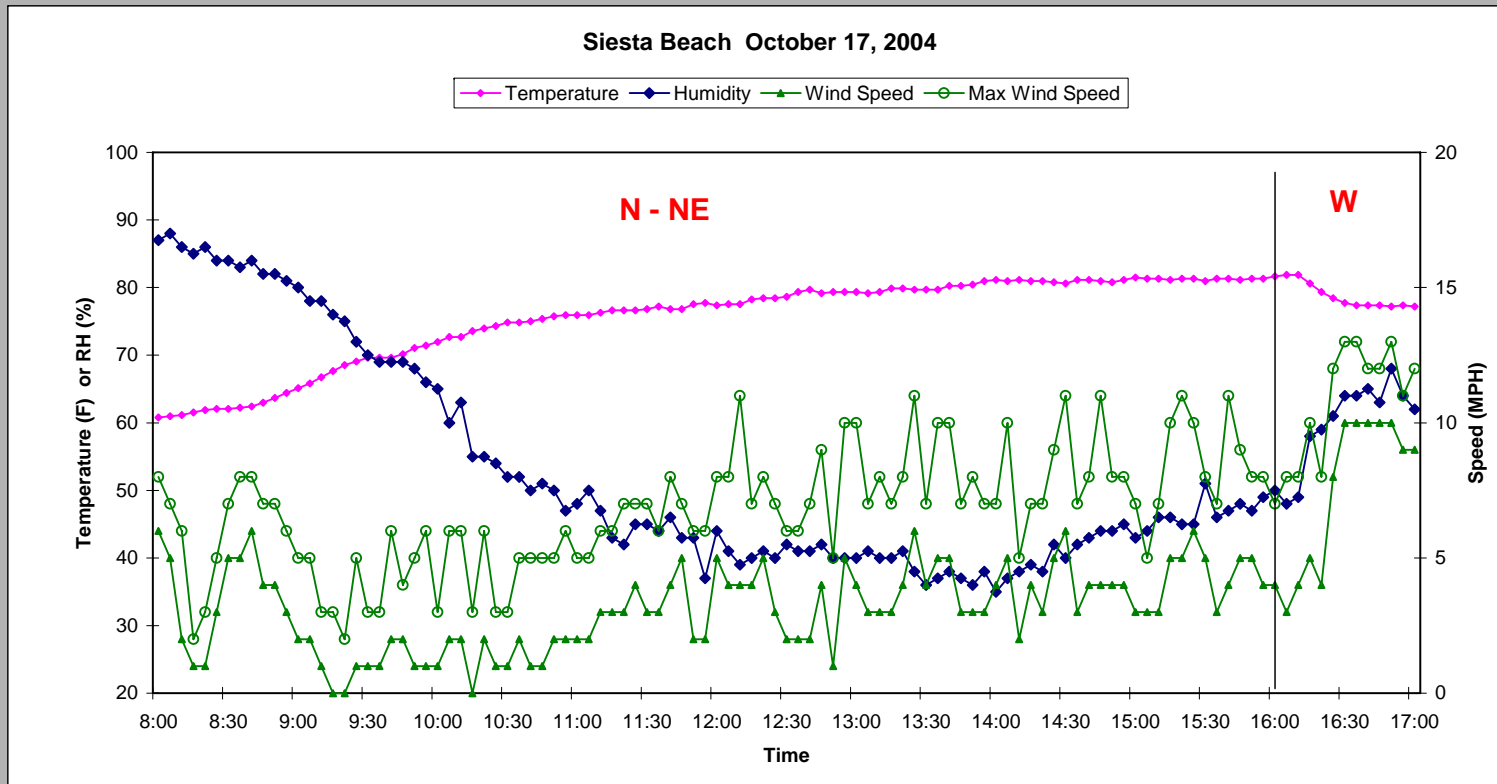

Hi-Vol Samplers

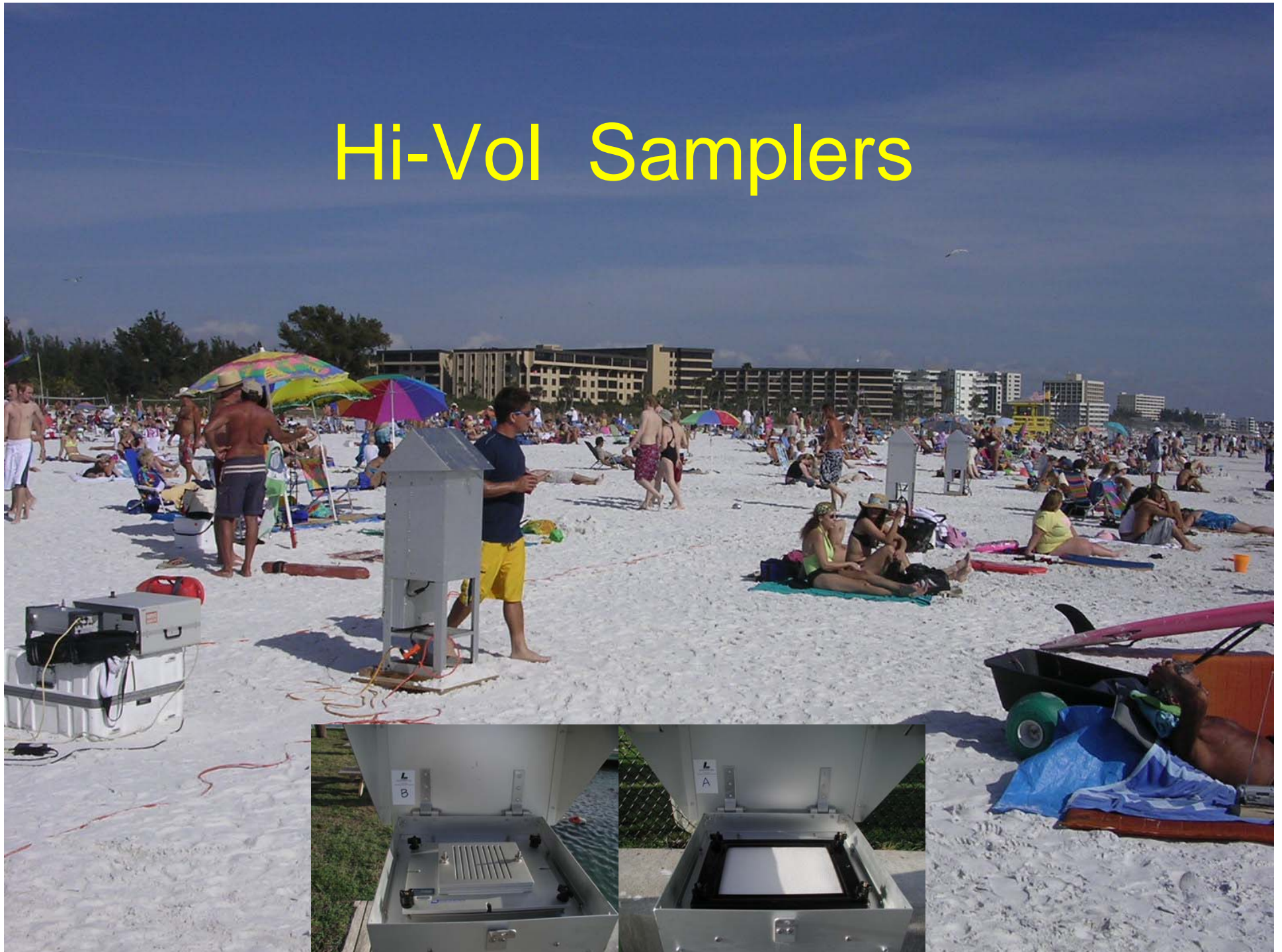

Air Concentration of PbTx by LCMS (ng/m³)

	Mean	SD
10/16/04	<LOD	<LOD
10/17/04	<LOD	<LOD
10/18/04	<LOD	<LOD
2/4/05	0.090	0.064
2/5/05	0.071	0.003
2/6/05	0.064	0.029
3/11/05	36.3	6.0
3/12/05	22.4	3.0
3/13/05	18.0	2.0
3/14/05	19.6	3.4

Brevetoxin Profile (ng/m³)

	Brevenal	PbTx-1	PbTx-2	PbTx-3	PbTx-6	PbTx-9
3/11/05	<LOD	4.0	20.6	14.8	0.4	2.2
3/12/05	<LOD	1.9	11.6	8.7	0.3	1.3
3/13/05	<LOD	1.3	11.7	5.8	0.2	1.2
3/14/05	<LOD	1.2	15.3	6.1	0.3	1.4

Temporary PbTx Concentration Profile

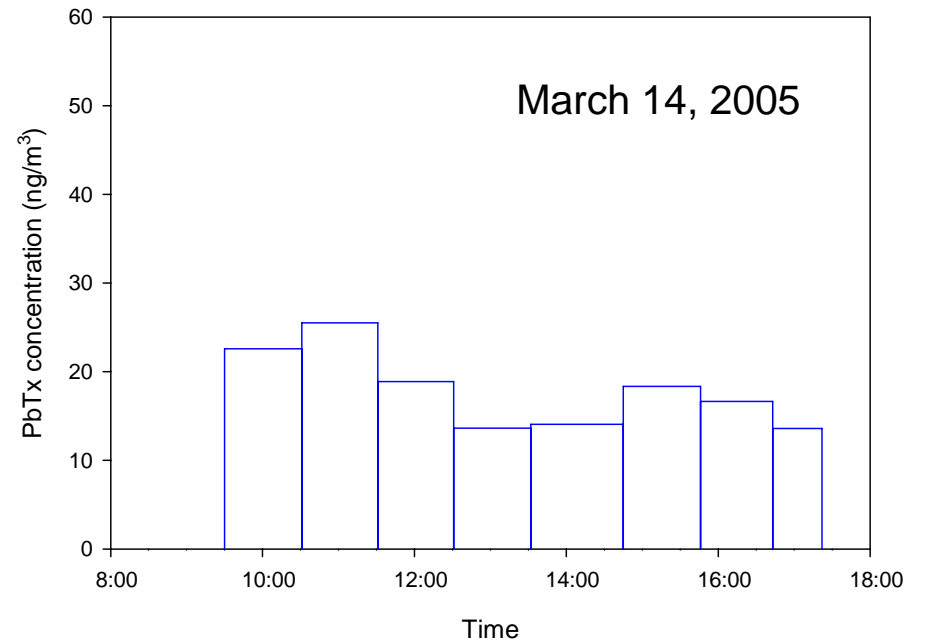
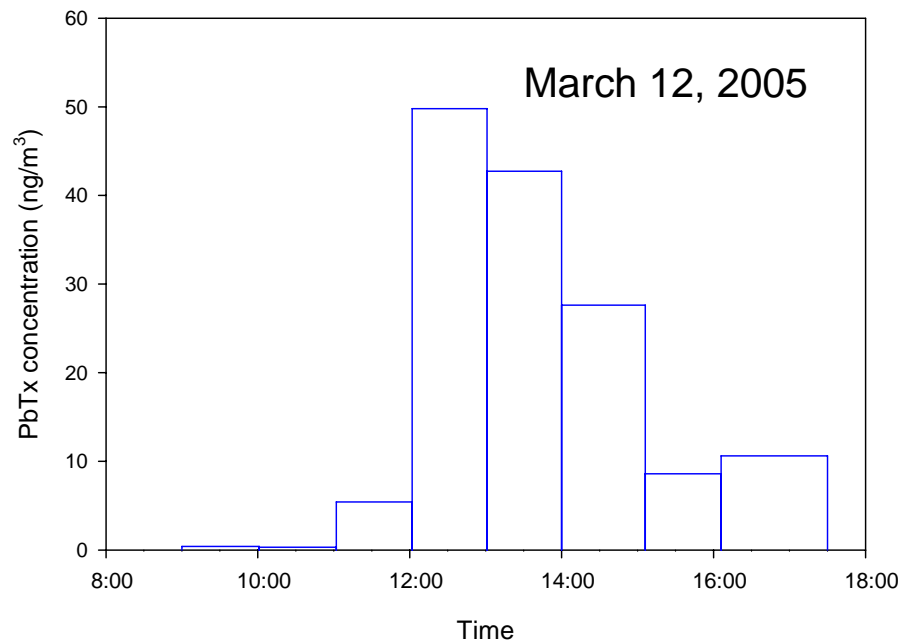
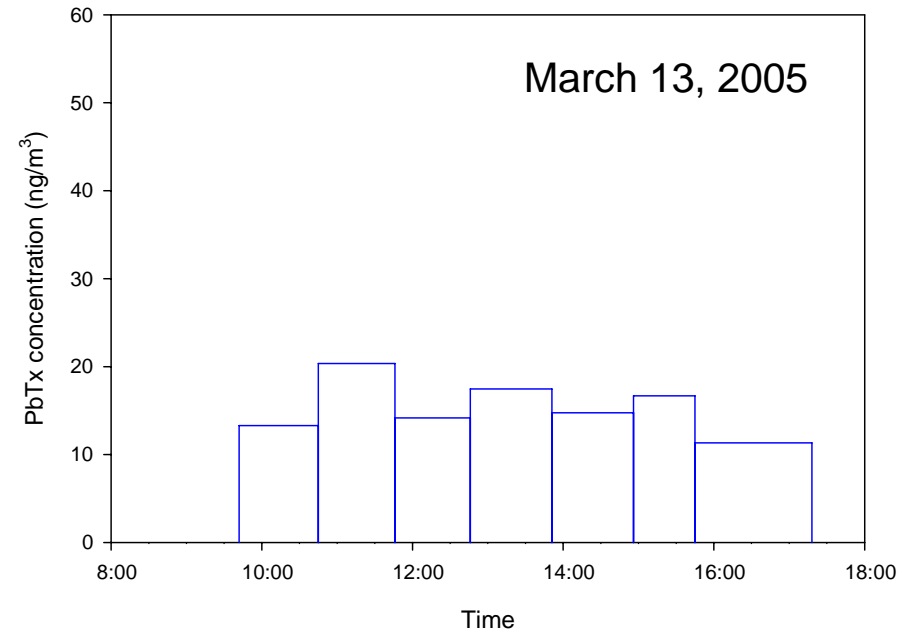
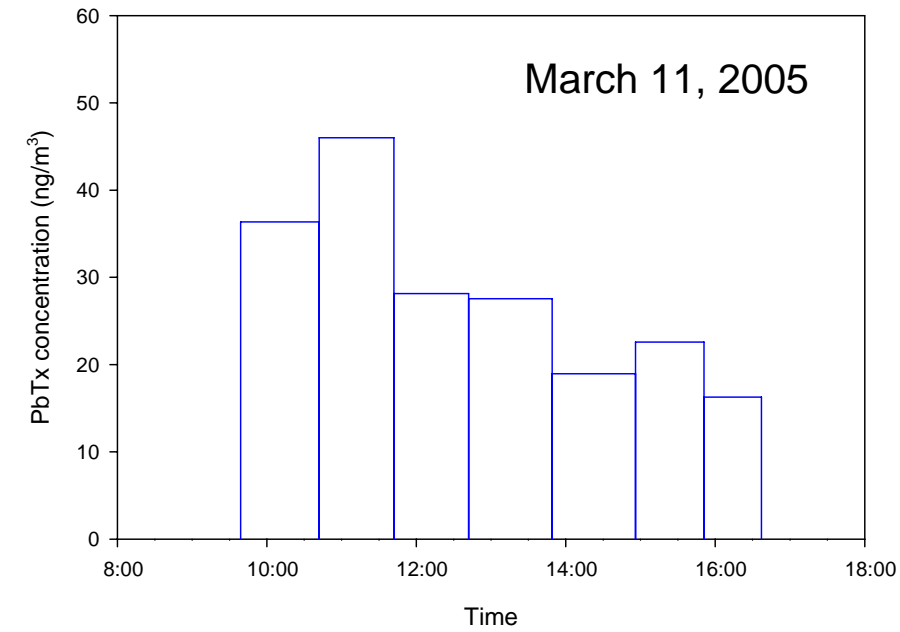

Air Sampler for Particle Size

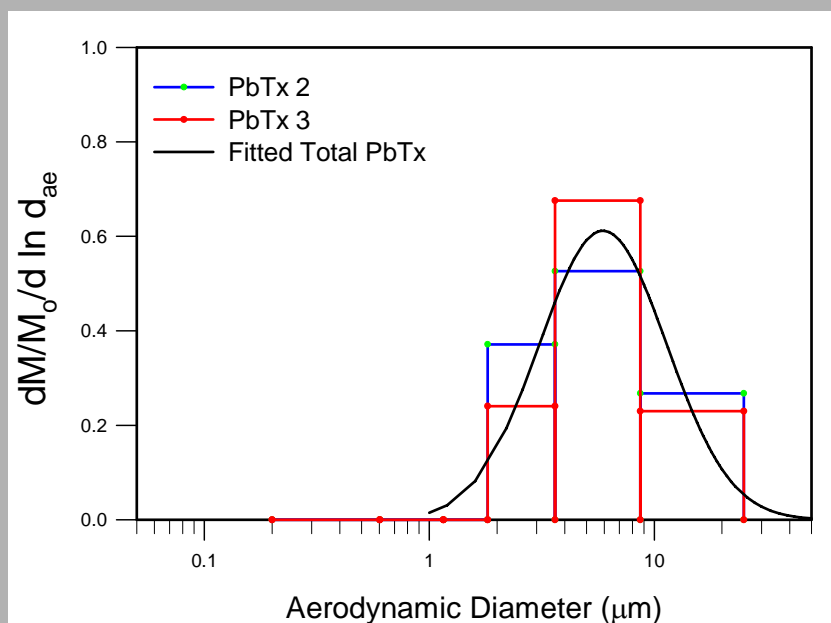
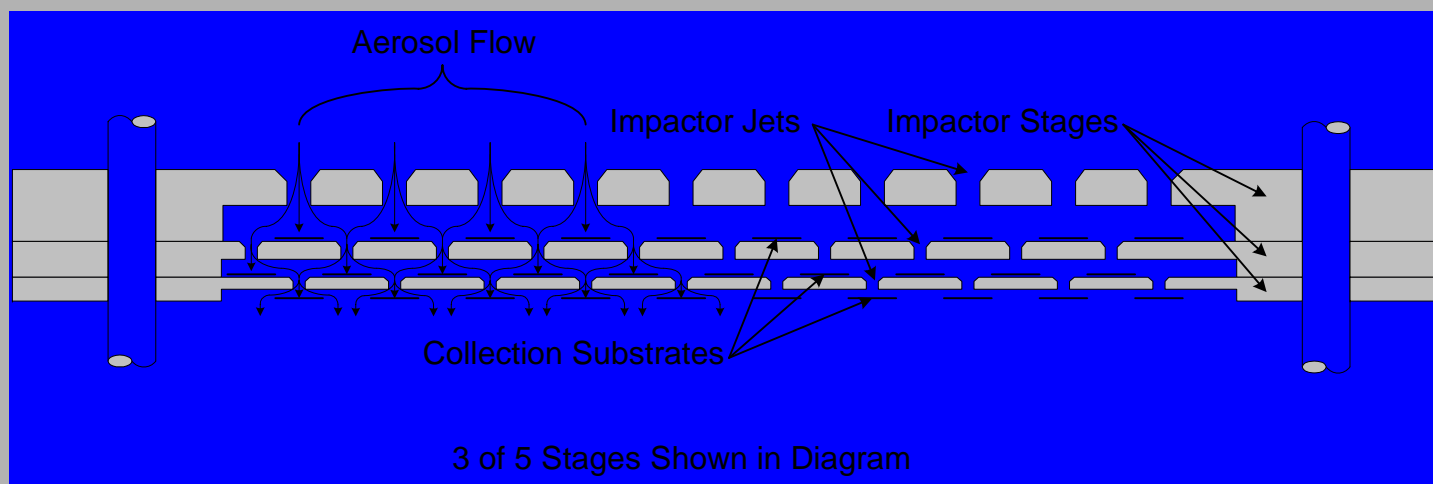

3/11/05

39.1 ng/m³

MMAD = 6.7 μm

GSD=1.90

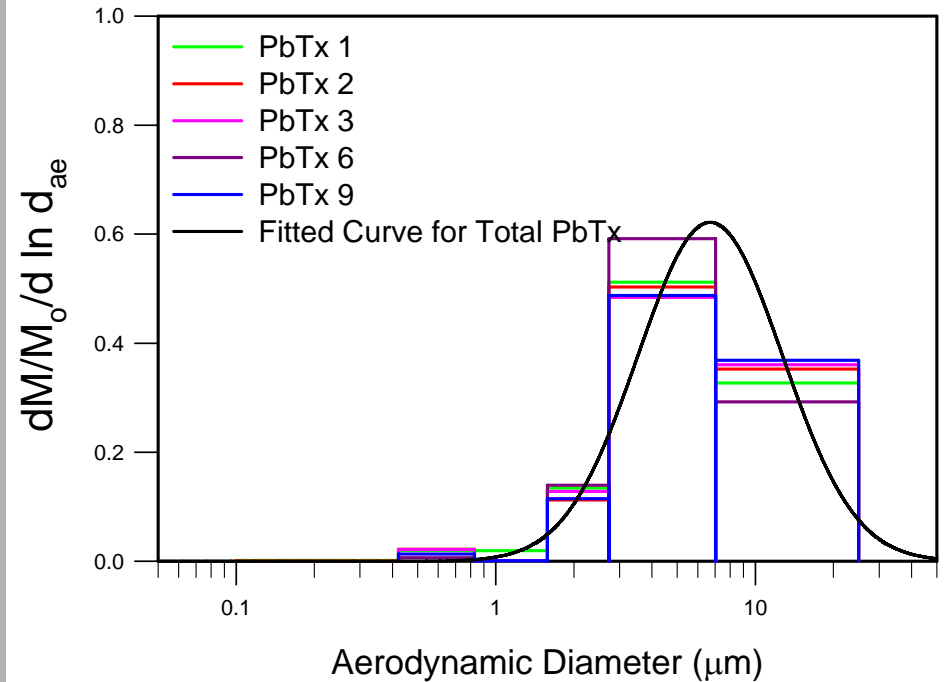

3/14/05

16.5 ng/m³

MMAD = 6.7 μm

GSD=1.75

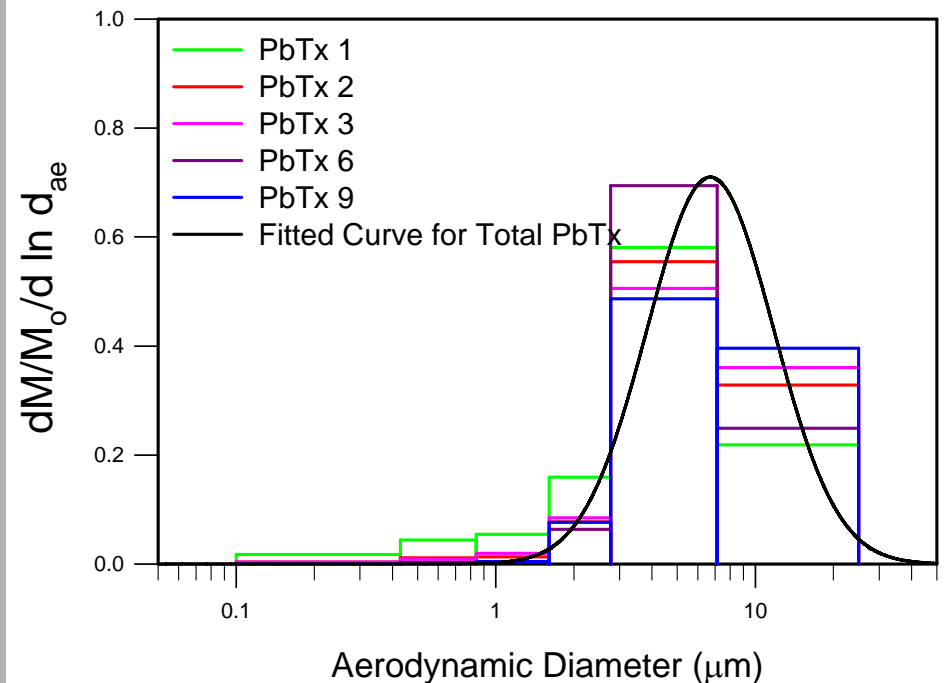

SUMMARY OF PARTICLE SIZE

	Impactor A		Impactor B	
	MMAD (μm)	GSD	MMAD (μm)	GSD
11-Mar-2005	6.42	1.81	6.70	1.90
12-Mar-2005	5.00	2.04	4.67	2.00
13-Mar-2005	6.32	1.82	6.49	1.78
14-Mar-2005	7.36	1.77	6.71	1.75

Real Time Aerosol Sampler

DataRAM

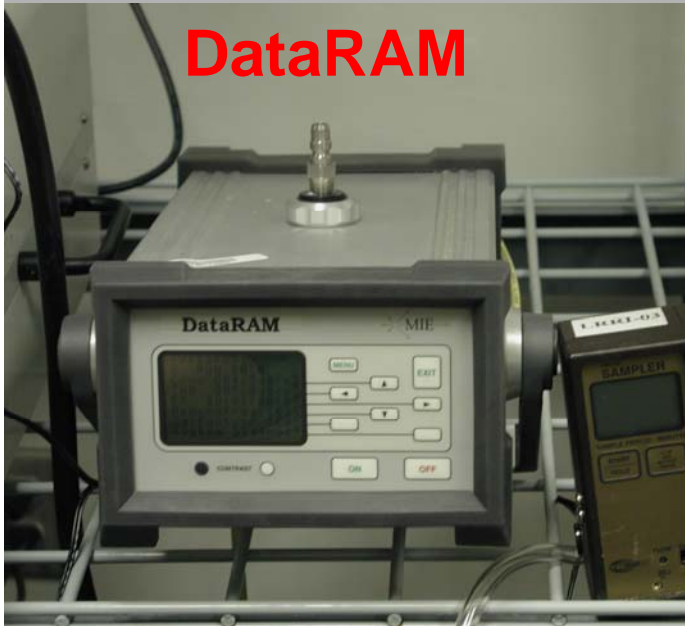

APS

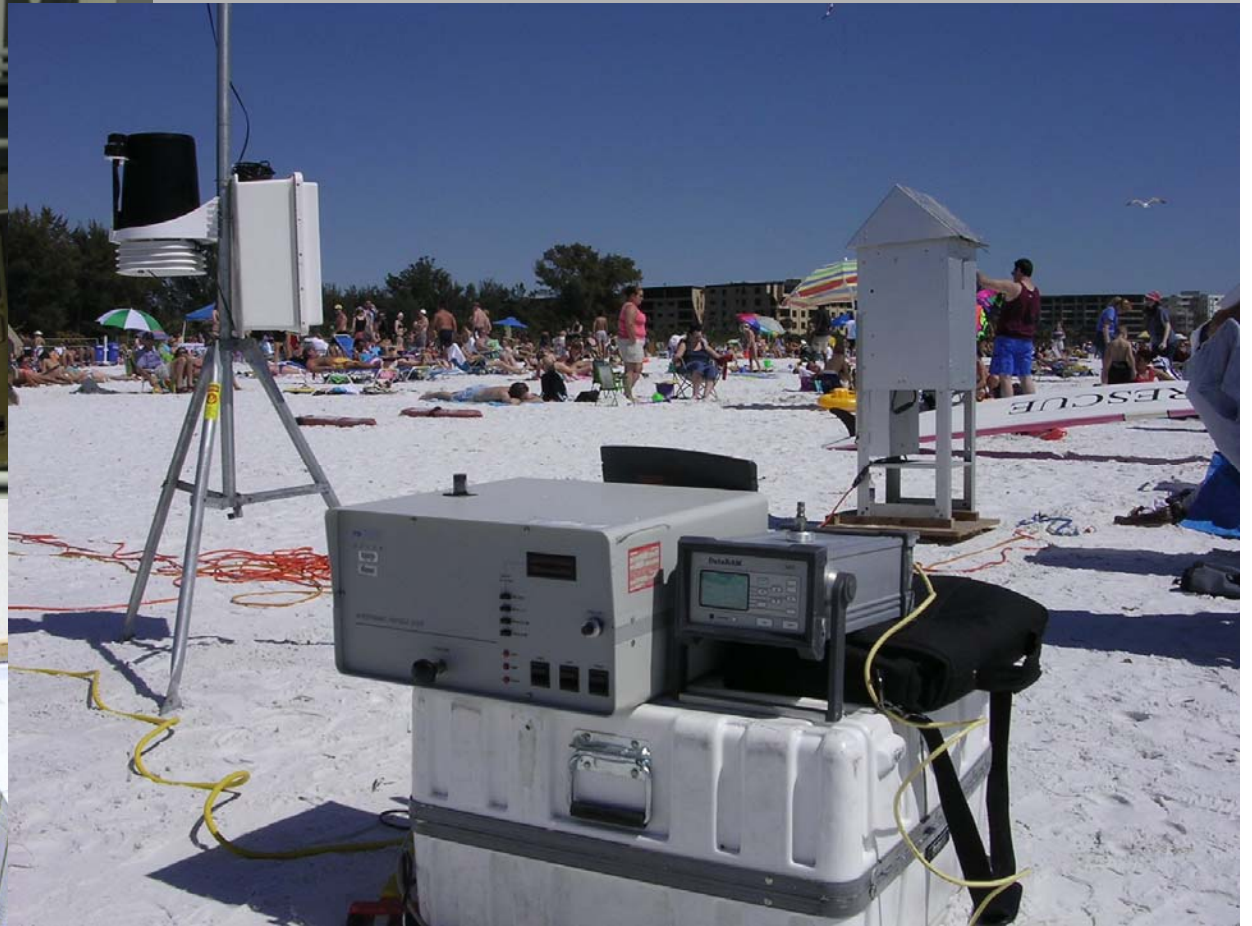
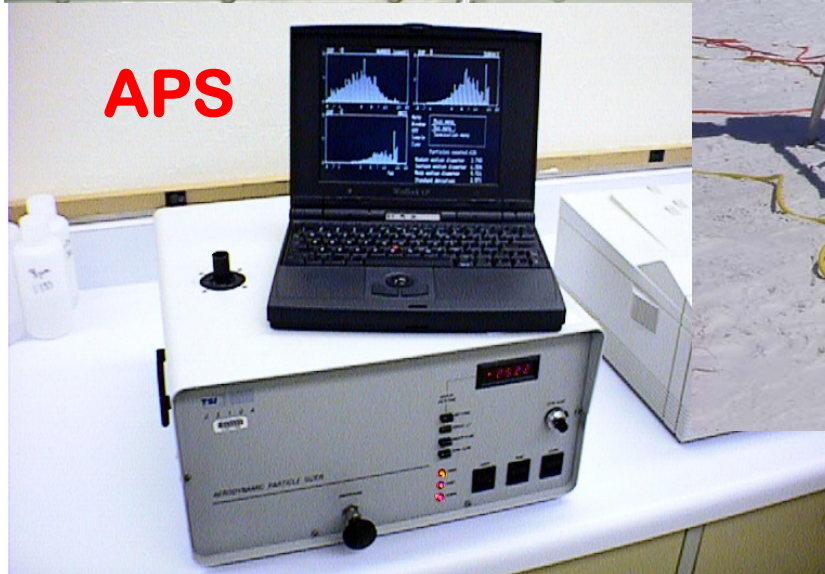

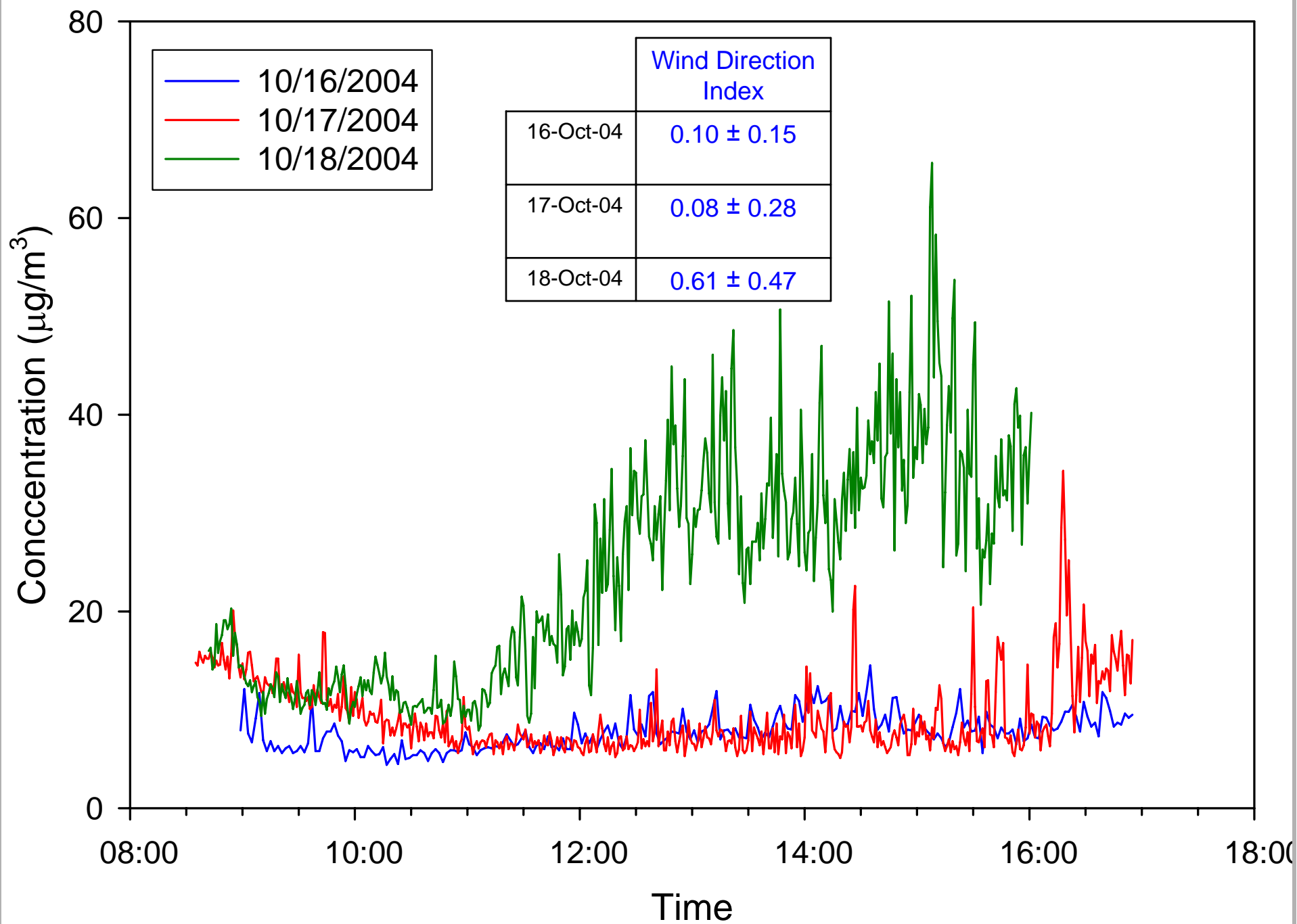

DataRAM and PbTx Concentrations

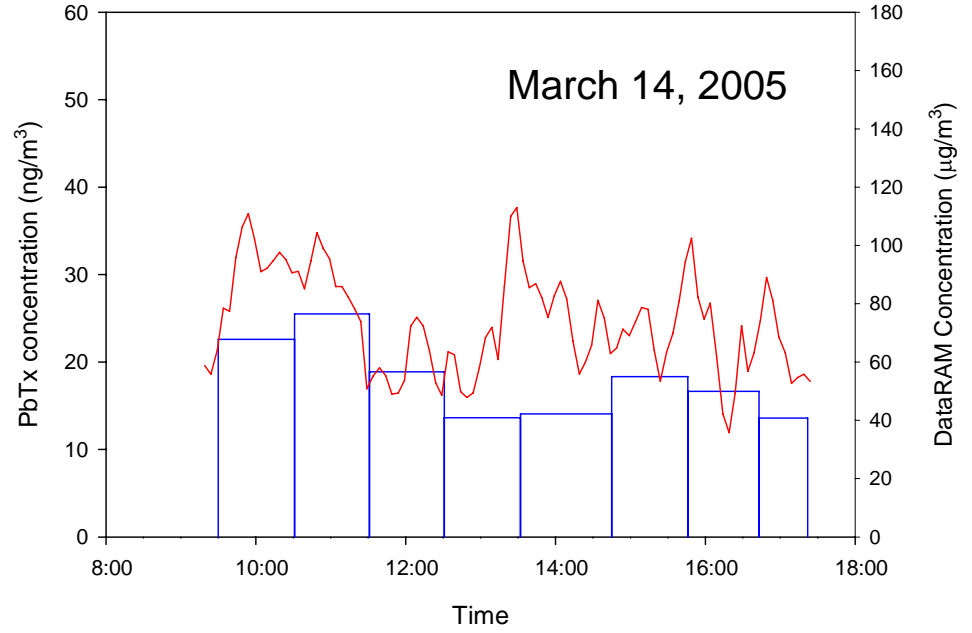
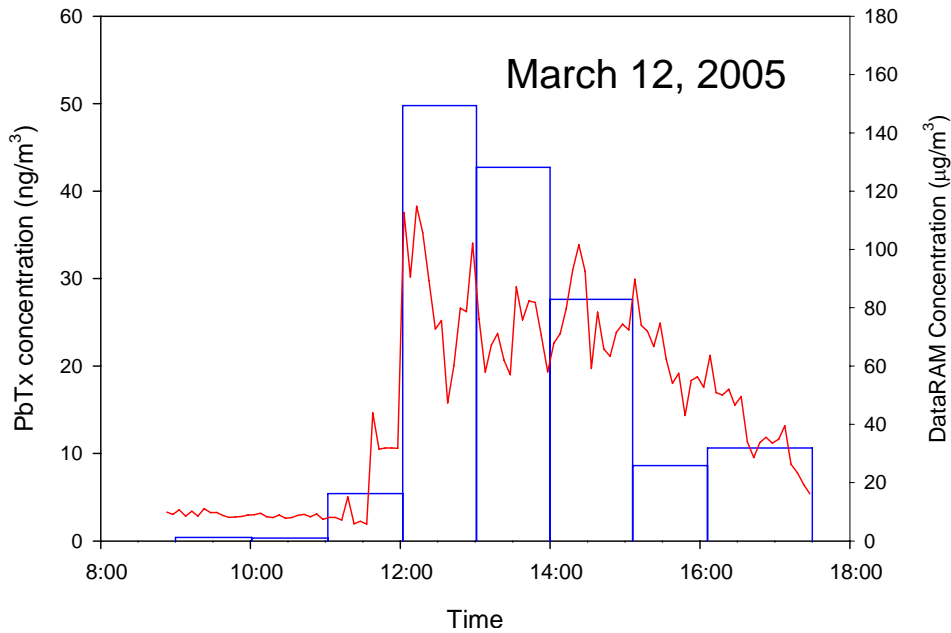
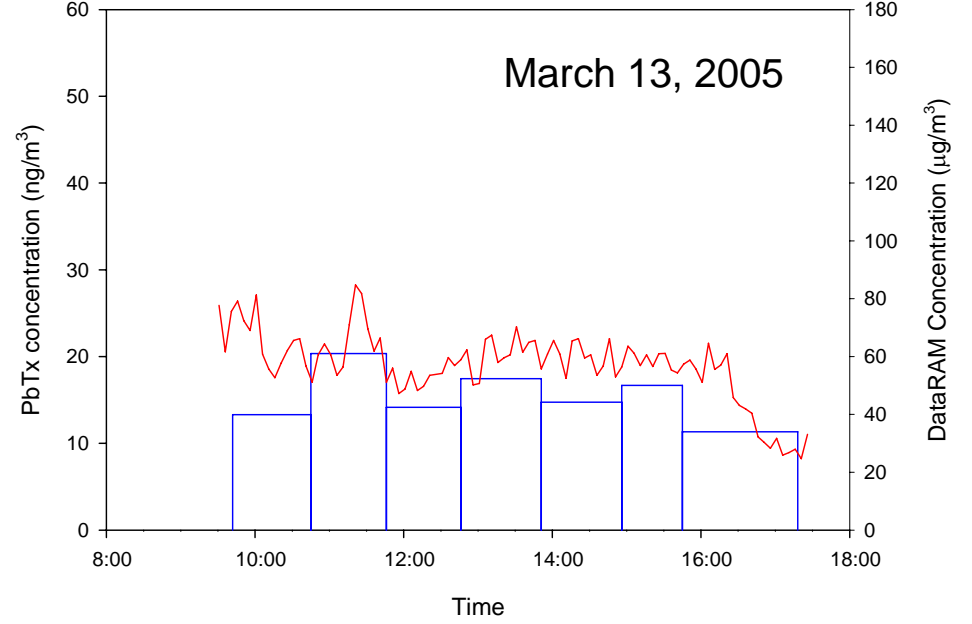
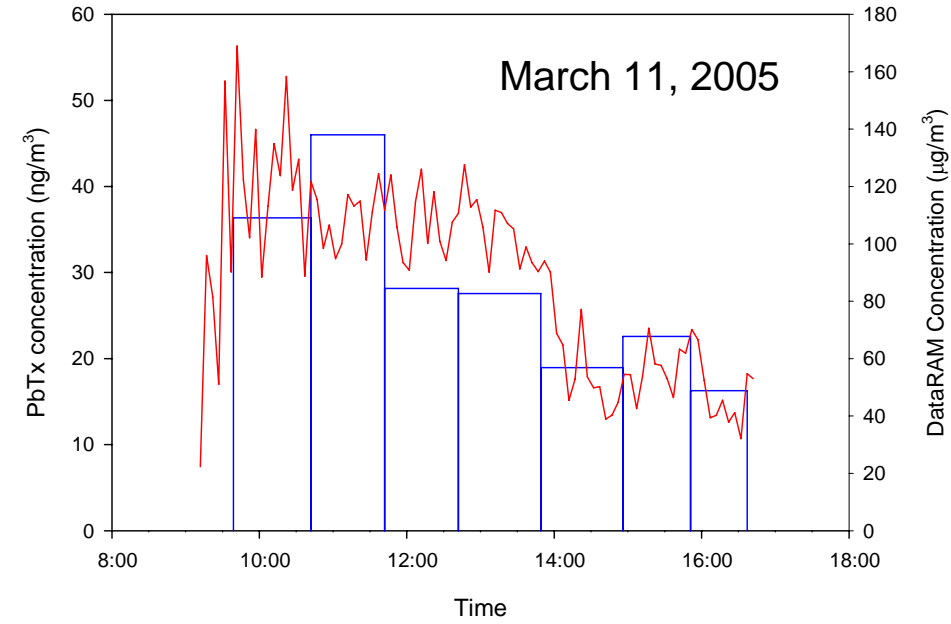

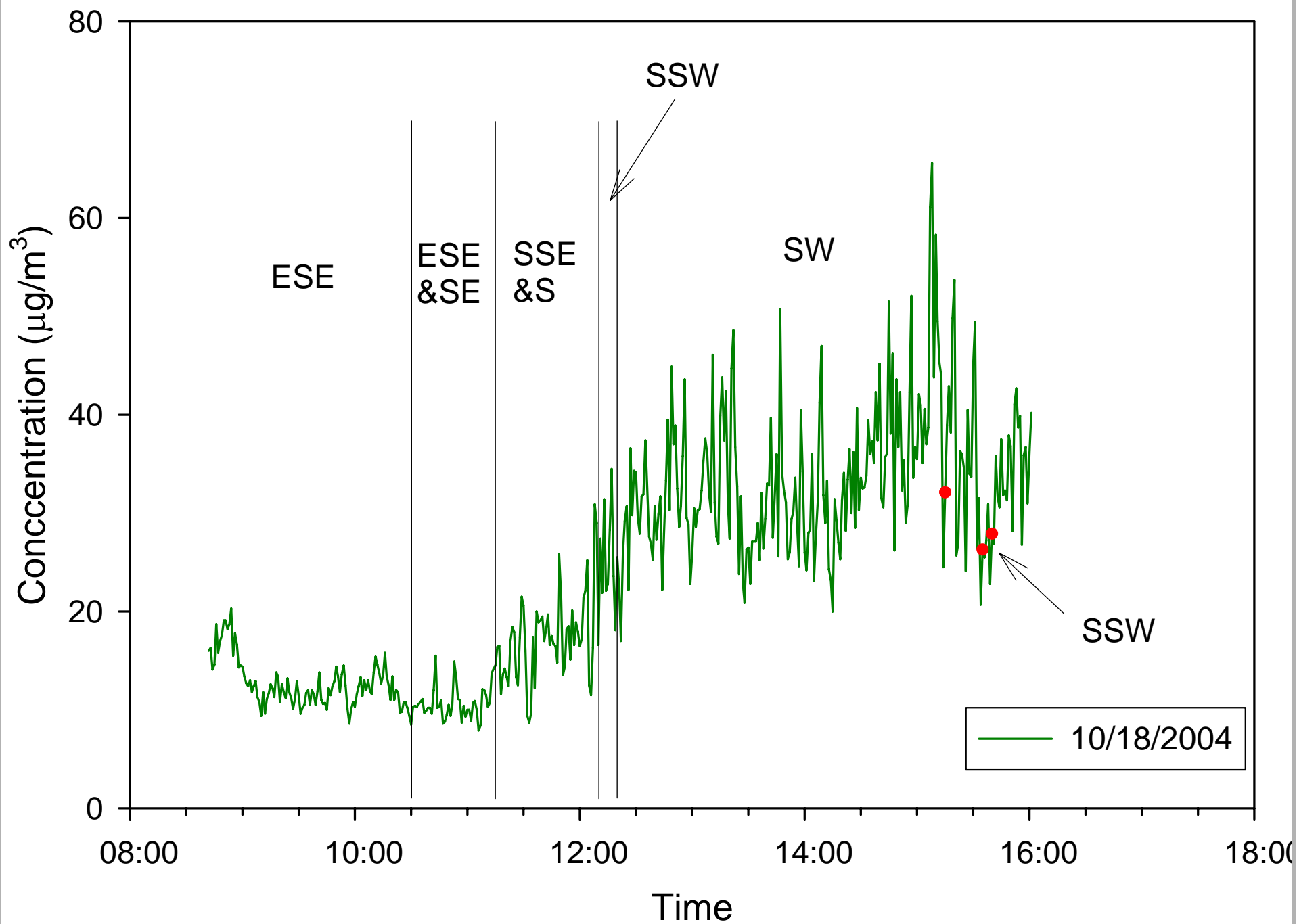

Aerosol Concentration and Wind Direction (October 2004)

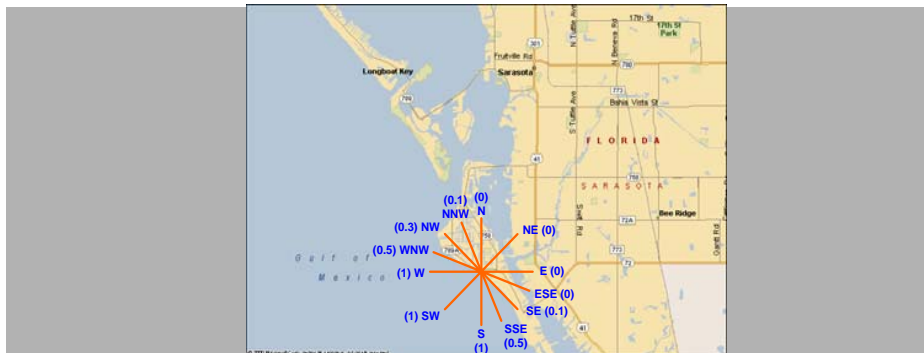
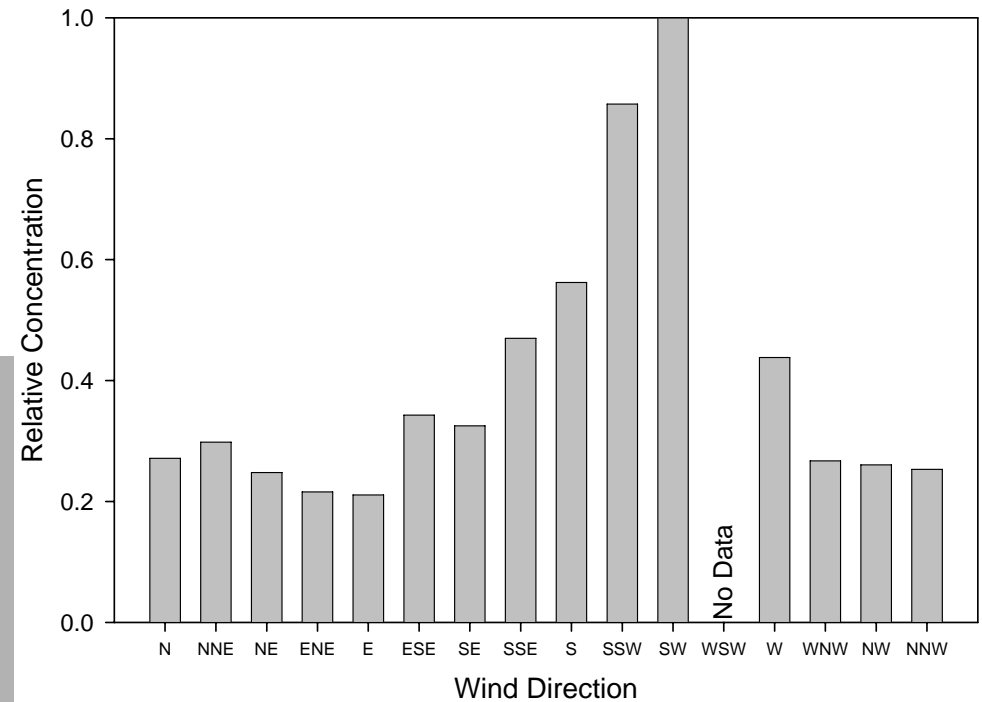
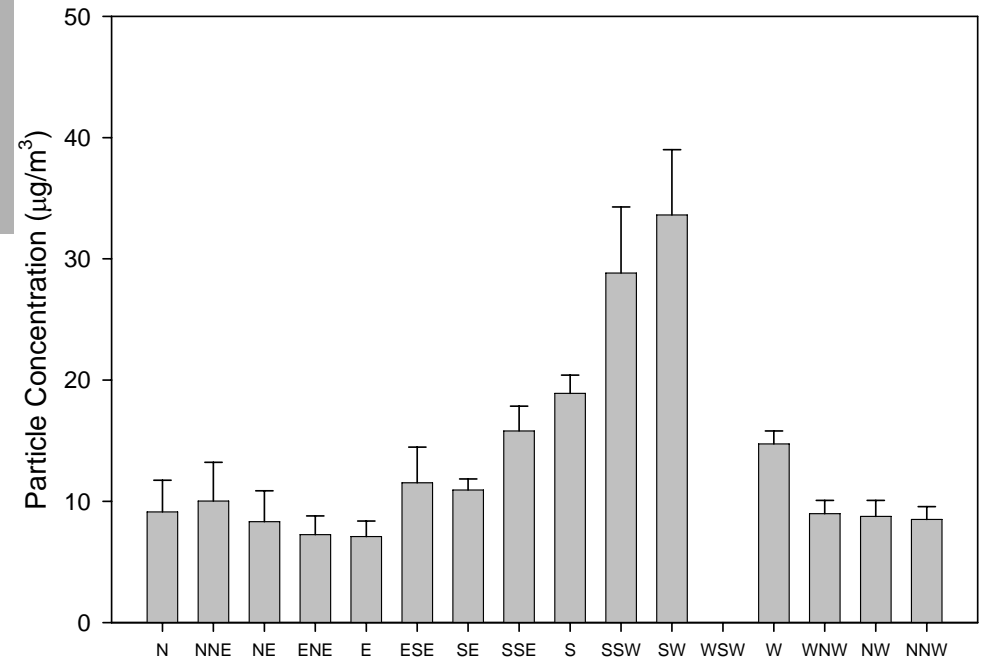
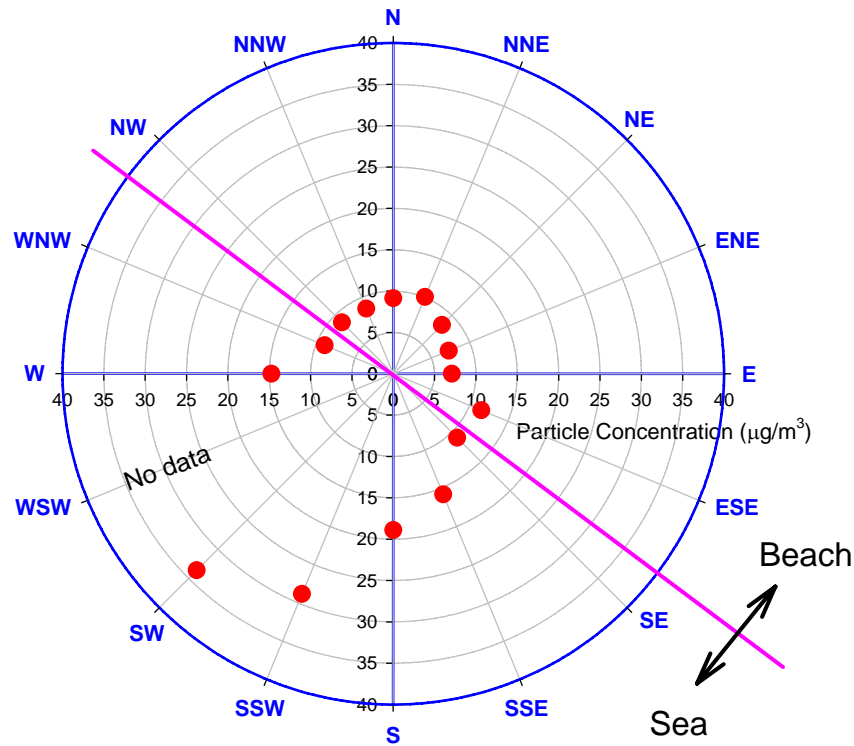

Relative Aerosol Concentration as a Function of Wind Direction

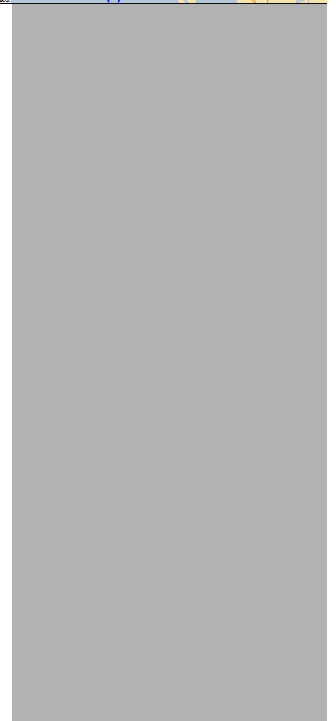
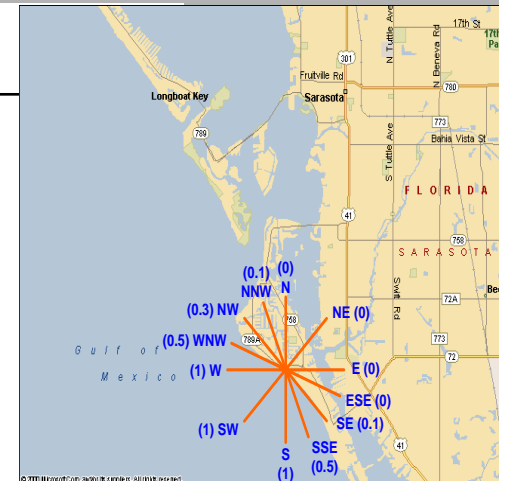
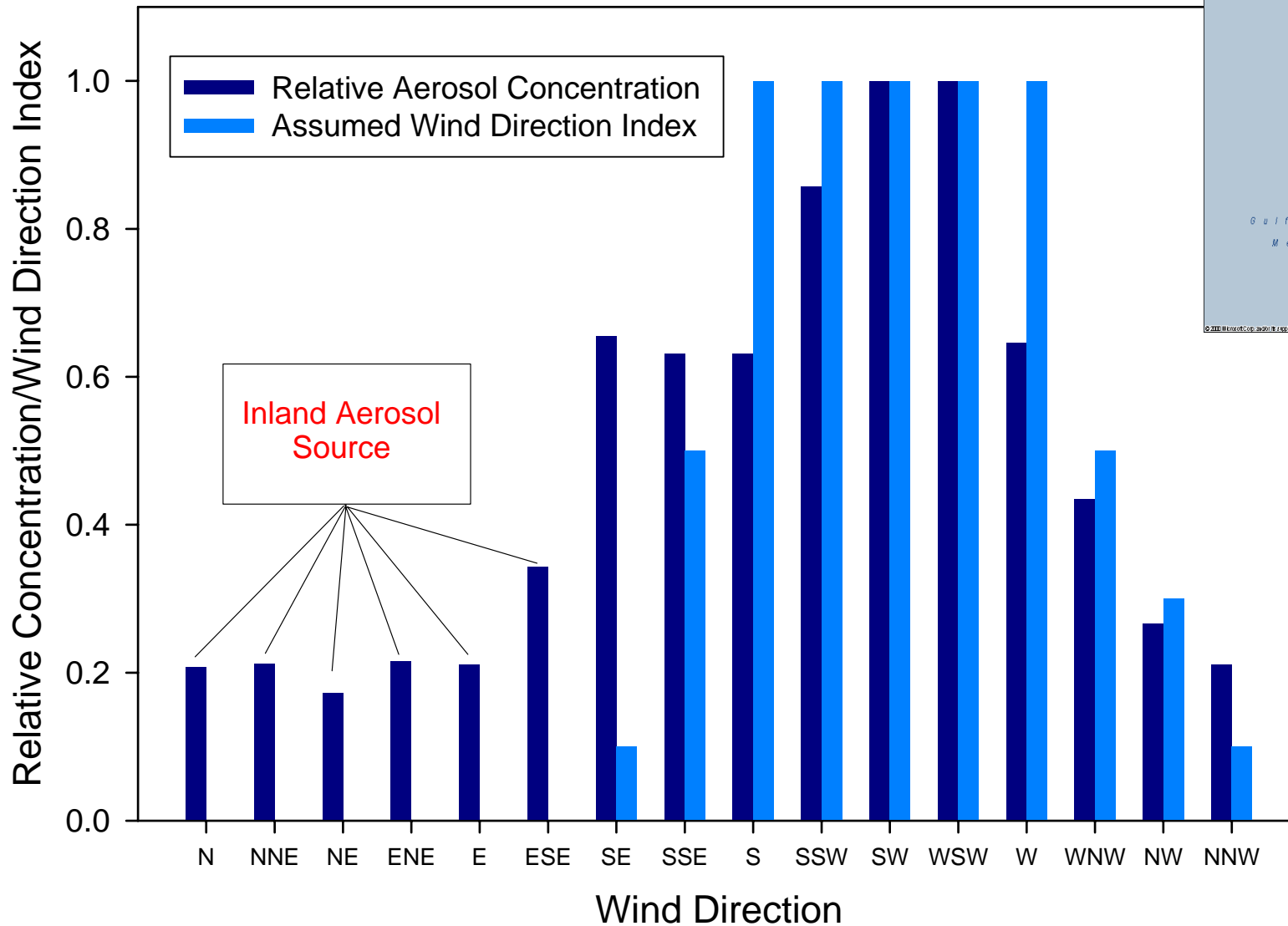

Revised Wind Direction Index Based on the DataRAM Information

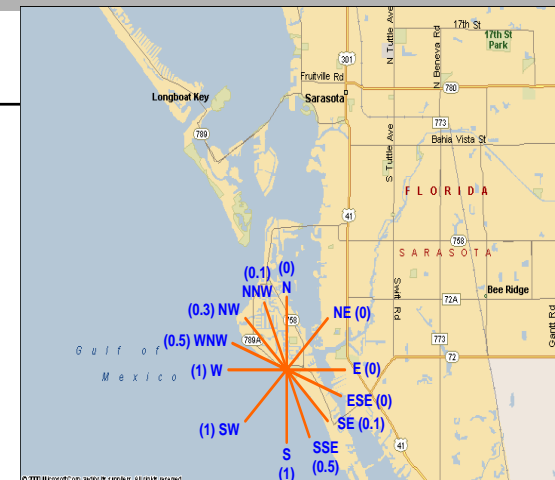
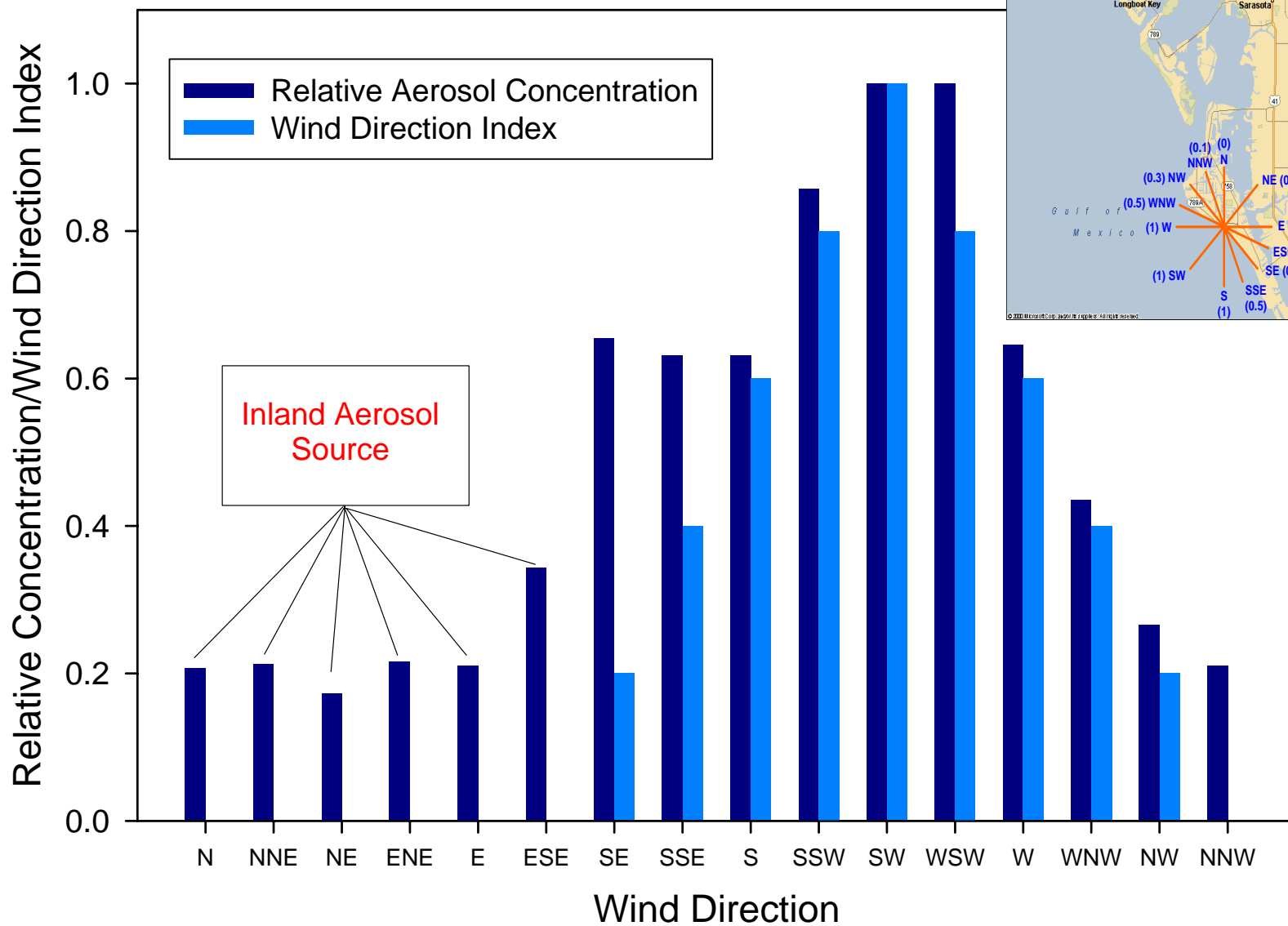

PbTx Concentration and Wind Direction

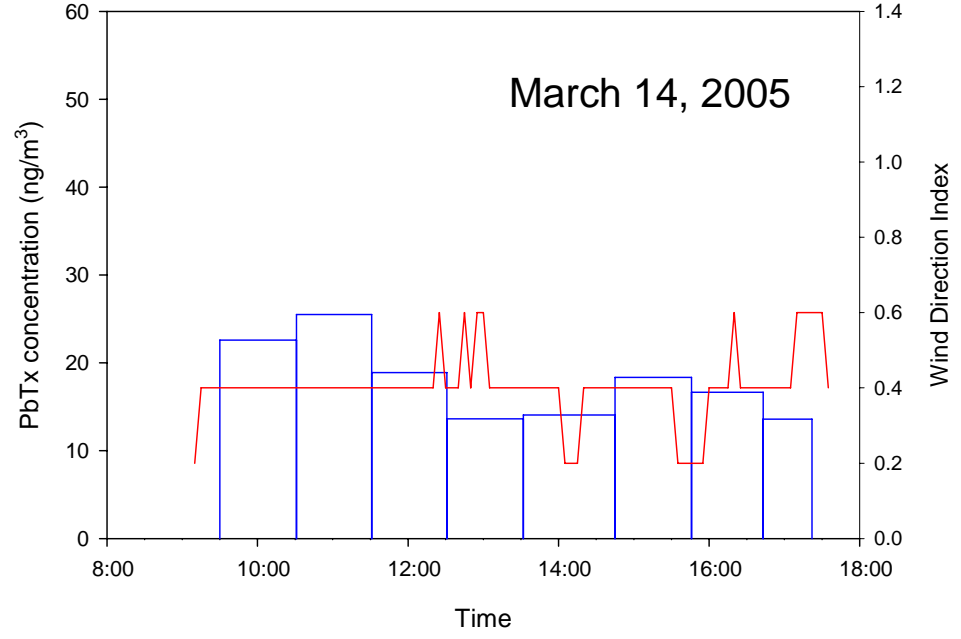
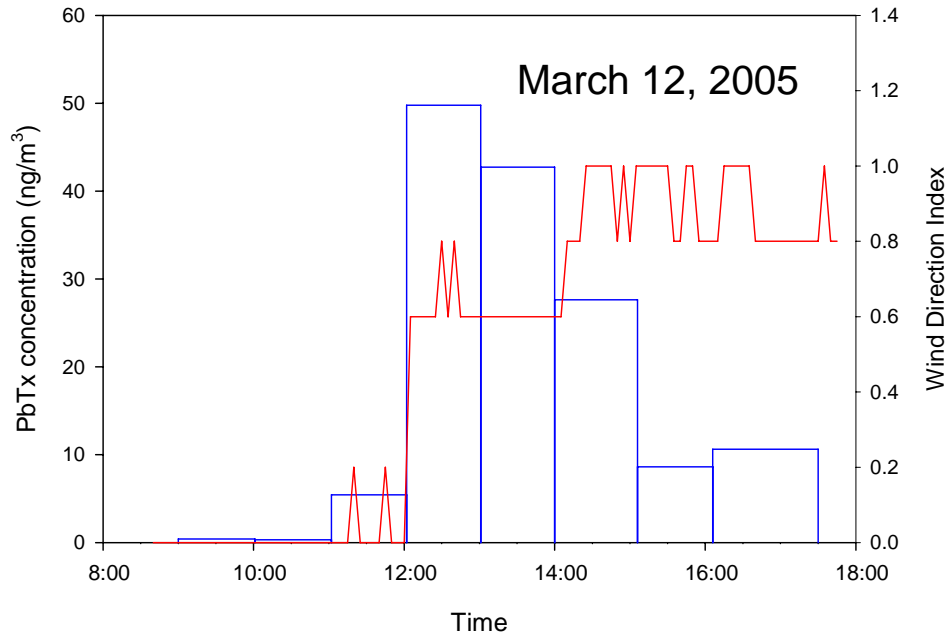
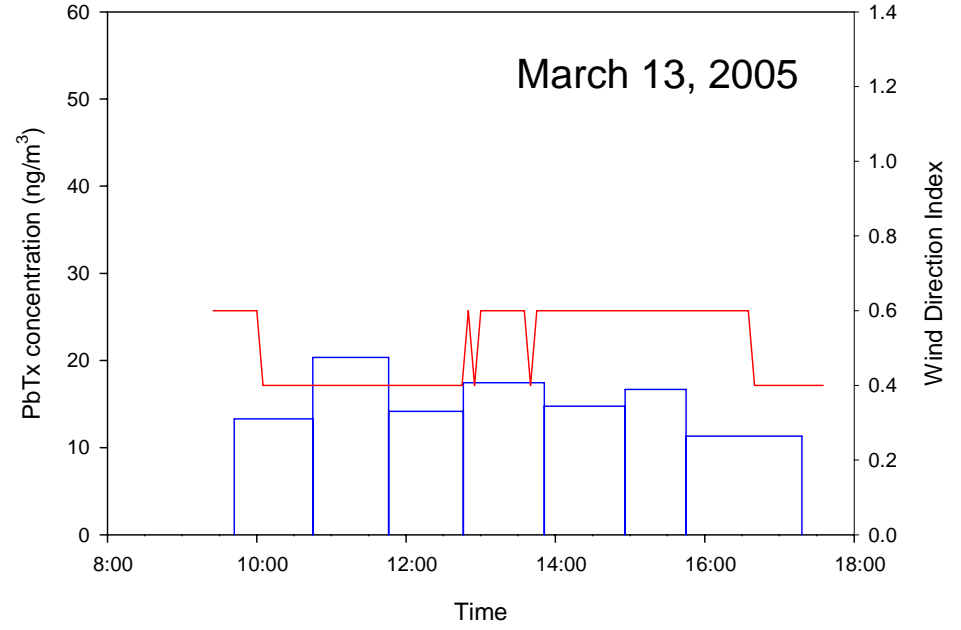
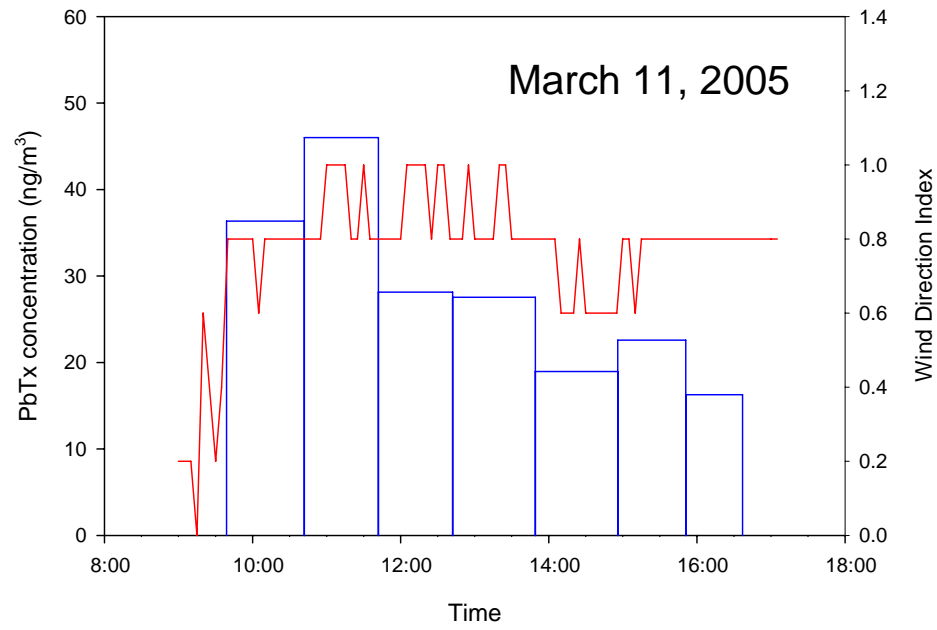

Personal Sampler



LOD = 1.5 ng/m³



LOD = 10 ng/m³



PERSONAL EXPOSURE CONCENTRATION

(ng/m³, ELISA ANALYSIS)

	Mean	SD	number of samples
10/16/2004	<LOD	<LOD	32
10/17/2004	<LOD	<LOD	31
10/18/2004	<LOD	<LOD	24
2/4/2005	<LOD	<LOD	29
2/5/2005	<LOD	<LOD	25
2/6/2005	<LOD	<LOD	44
3/11/2005	31.1	18.5	21
3/12/2005	58.1	36.9	22
3/13/2005	19.6	14.6	29
3/14/2005	13.9	10.6	19

Blue Green Algae

- **Laboratory Study**
 - Evaluation of ELISA method
 - Validation of aerosol sampling methods
 - Aerosol measurement

- **Field Study**



Validation of ELISA Method (Microcystin LR)

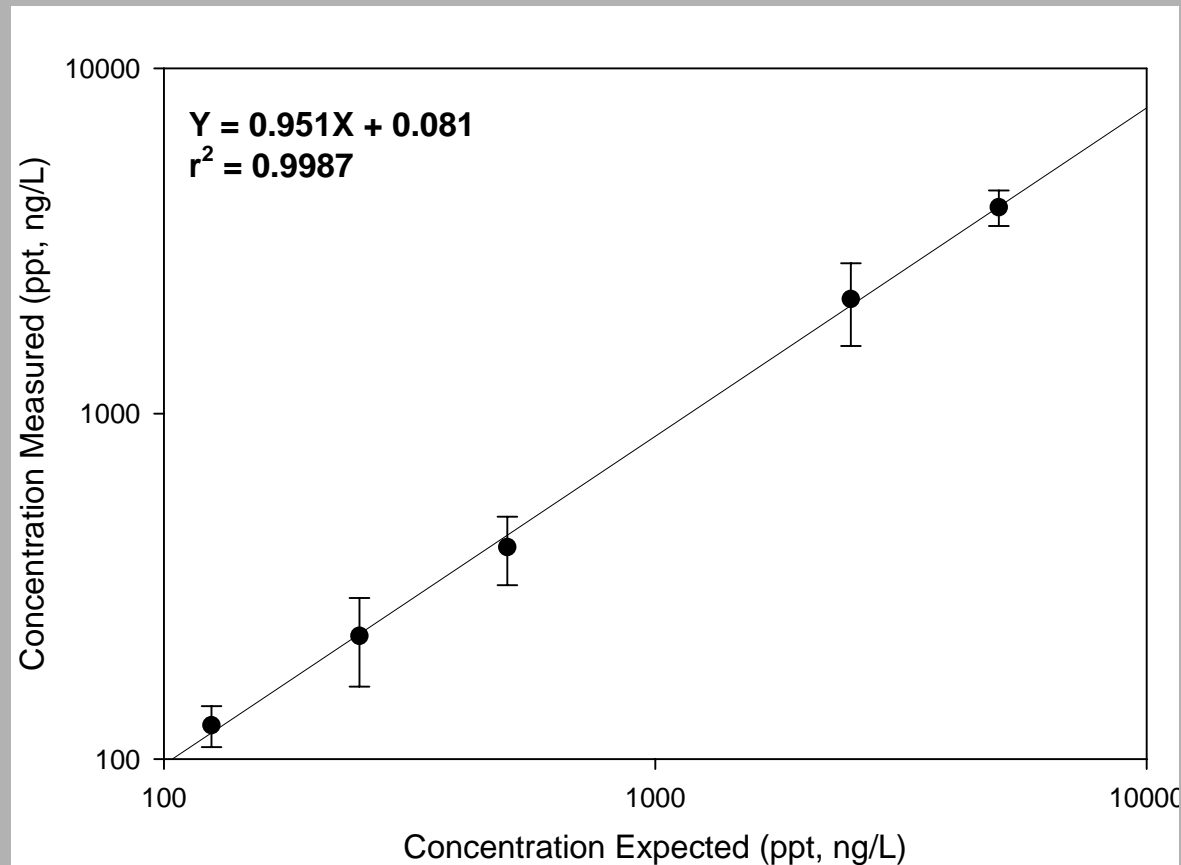

Extraction Efficiency of Microcystin for Cellulose Filter

Concentration ppt (ng/L)	Spike mass (ng)	Remaining vol. (μ L)	Microcystin obtained by ELISA* (ng/L)	Extraction mass* (ng)	Extraction efficiency* (%)
50000	5.00	800	6914 \pm 948	5.53 \pm 0.76	110.6 \pm 15.2
25000	2.50	800	2550 \pm 231	2.04 \pm 0.18	81.6 \pm 7.4
10000	1.00	800	1032 \pm 158	0.83 \pm 0.13	82.6 \pm 12.7
5000	0.50	800	582 \pm 119	0.47 \pm 0.10	93.1 \pm 19.1
2500	0.25	800	272 \pm 95	0.22 \pm 0.08	86.9 \pm 30.5
1000	0.10	800	104 \pm 25	0.08 \pm 0.02	82.8 \pm 19.8
				Mean	89.7
				SD	11.1

Laboratory Aerosol Study

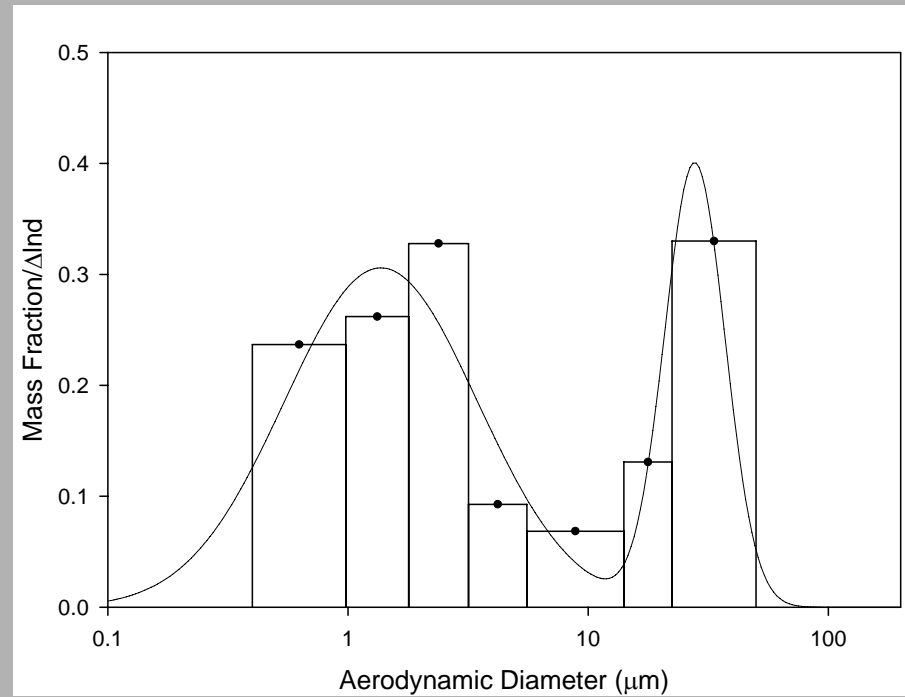
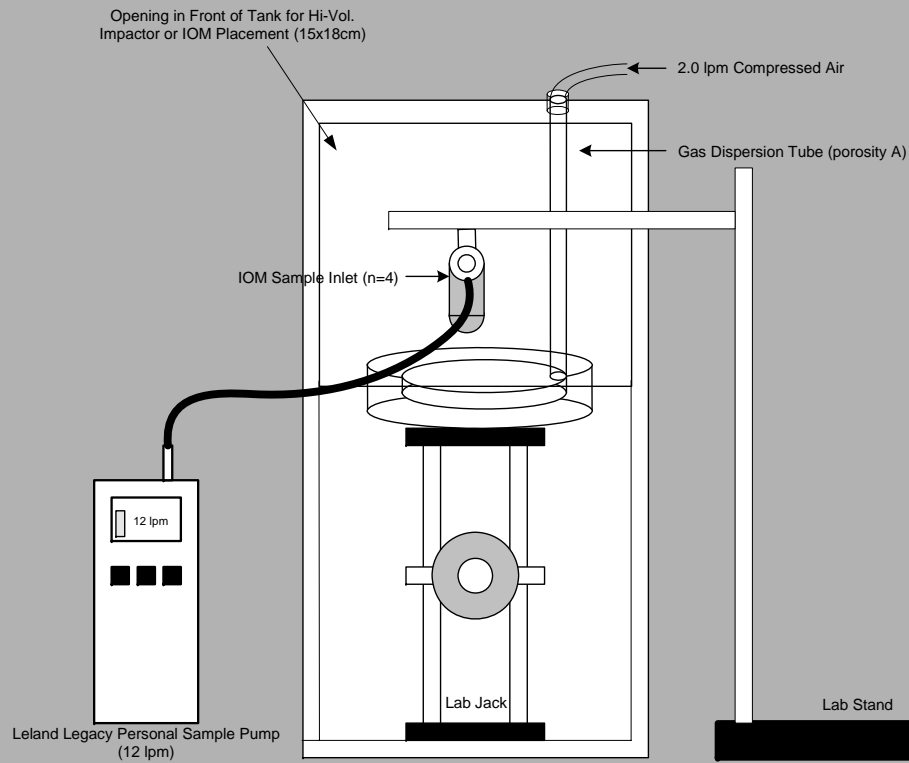

Personal Samples 0.14 to 0.26 ng/m³
100 ng/L solution

SUMMARY

- **Red tide aerosol exposure depends on**
 - **Water concentration of PbTx**
 - **Wind direction**
- **Personal exposure measurement has improved with the new pump**
- **Similar sampling techniques can be used in the study of exposure assessment of aerosolized blue green algae**

PARTICIPANTS

Lovelace Respiratory Research Institute

Yue Zhou, Mitch Irvin, Hammad Irshad

Dean Kracko, Jake McDonald

Mote Marine Laboratory

Richard Pierce, Mike Henry,

Barbara Kirkpatrick

UNC, Wilmington, Center for Marine Science

Jerome Near, Andrea Bourdelaisa

Florida DOH

Andy Reich

CDC

Lorri Backer

